

HOSE FOR END OF TRAIN DEVICE “EOT HOSE”

FRA requirement: Hose ID shall be 5/8” to effect an emergency brake application
 (Code of Federal Regulations, Title 49, Volume 4, 2004, 49CFR232.405)

STRATO P/N TBD

FORMER

NEW

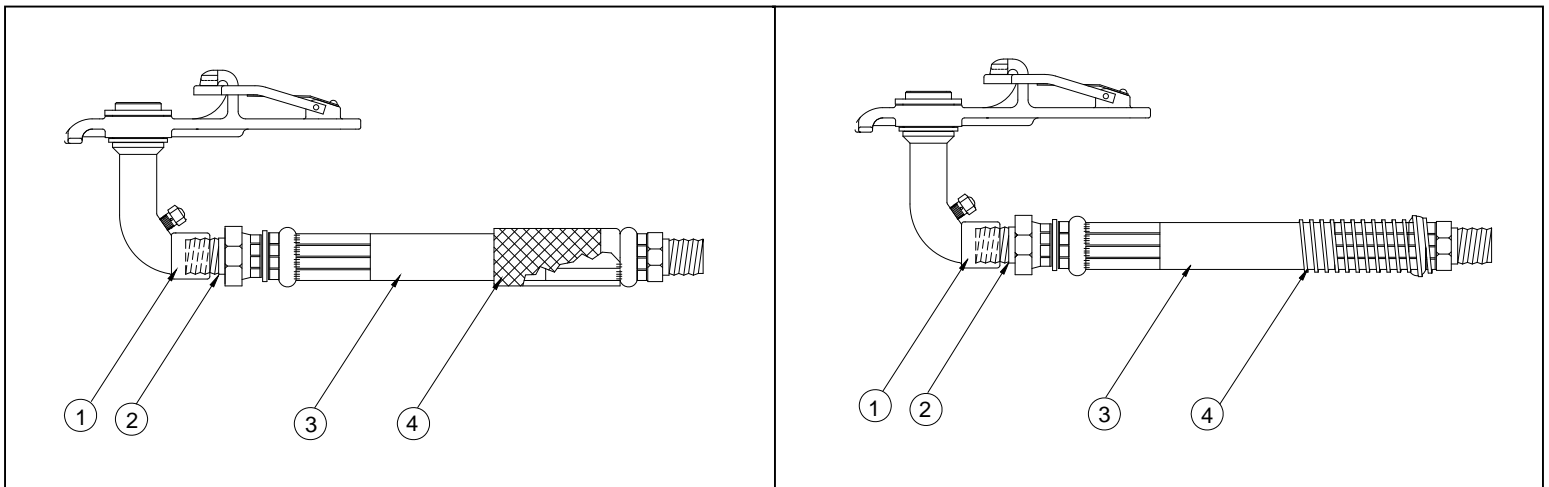

	FORMER	NEW	BENEFIT
1	90° ELBOW HAS 1/2" NPTF PORT	90° ELBOW HAS 3/4" NPTF PORT	LARGER FITTING ID FOR 41% GREATER AIR FLOW THROUGH HOSE
2	HOSE FITTING HAS 1/2" NPTF SWIVEL	HOSE FITTING HAS 3/4" NPTF SWIVEL	41% GREATER AIR FLOW THROUGH HOSE
3	5/8" HOSE ID	3/4" HOSE ID	41% GREATER AIR FLOW THROUGH HOSE
4	TYGON TUBING HOSE RESTRAINT	WIRE GUARD HOSE RESTRAINT	IMPROVED KINK PROTECTION BEHIND HOSE FITTING