

THIS DRAWING IS THE PROPERTY OF STRATO, INC.
 THIS DRAWING IS LOANED UPON THE EXPRESS CONDITION THAT IT
 SHALL NOT BE REPRODUCED IN ANY MANNER, AND SHALL BE RETURNED
 UPON DEMAND. IT IS SUBMITTED FOR EVALUATION PURPOSES ONLY.
 INFORMATION CONTAINED THEREIN, SHALL NOT BE USED, OR
 DISCLOSED TO THIRD PARTIES WITHOUT THE WRITTEN CONSENT OF
 STRATO, INC

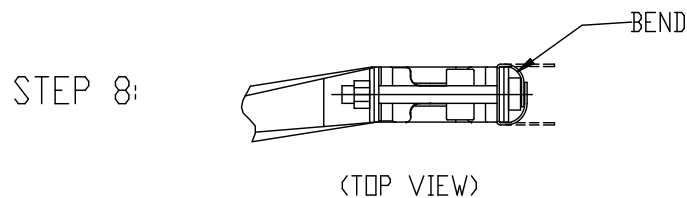
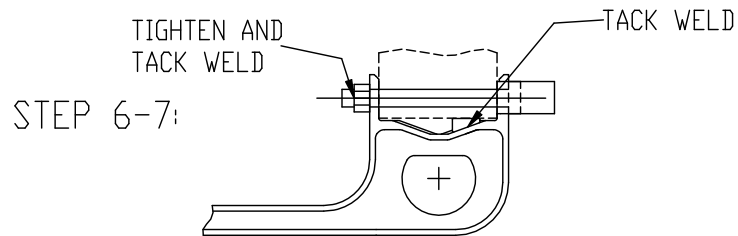
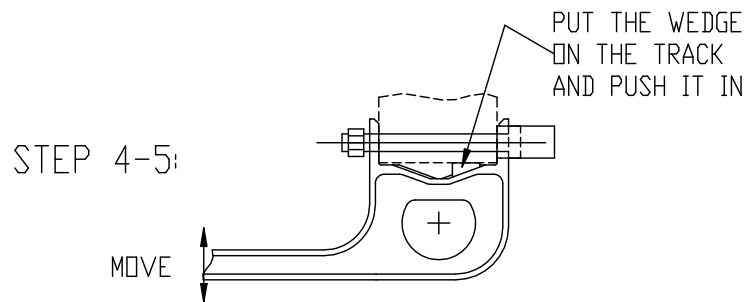
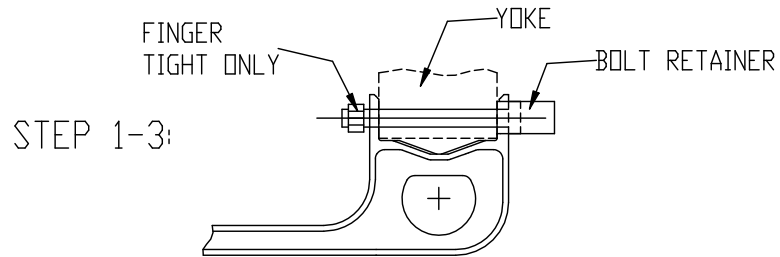

STRATO INSTALLATION PROCEDURE

(REFER TO STRATO DRAWING FE0C-F43BA-CUST)

1. HOLD THE BRACKET AT THE APPROPRIATE POSITION, MAKE SURE THE BOLT RETAINER IS FACING OUTSIDE.
2. PUT THE BOLT ($\phi 7/8"$) IN FROM THE BOLT RETAINER'S SIDE AND GO THROUGH THE BRACKET AND THE YOKE.
3. PUT THE NUT ON THE BOLT, ONLY FINGER TIGHT. DO NOT TIGHTEN IT AT THIS TIME.
4. PUT THE WEDGE ON EITHER SIDE OF THE TRACK OF THE BRACKET.
5. MOVE THE BRACKET UP AND DOWN AND PUSH THE WEDGE INSIDE AS FAR AS IT CAN GO.
6. TACK WELD THE WEDGE ON THE BRACKET.
7. TIGHTEN THE NUT AND TACK WELD IT ON THE BOLT.
8. BEND THE BOLT RETAINER OVER THE BOLT HEAD WITH HAMMER TO RETAIN THE BOLT TIGHTLY.
9. PIVOT THE BRACKET ABOUT THE BOLT AND MAKE SURE THE DEVIATION IS LESS THAN $1/4"$. (NOT SHOWN)



FE0C-F43BA-IW

NEXT HIGHER ASSEMBLY	 Quality Railroad Products		100 New England Avenue Piscataway, N.J. 08854	
X			SD-70 REV. A	
REFERENCE DRAWINGS	DESCRIPTION			
	INSTALLATION GUIDE FOR FE0C-F43BA			
UNLESS OTHERWISE SPECIFIED TOLERANCES ARE AS FOLLOWS:	DRAWN BY	CHECKED BY	DATE CREATED	REV. DATE
FRACTIONS — $\pm 1/64"$	LH	LMH	1/28/04	
TWO PLACES — ± 0.010	SCALE	DWG. NO.	REV	
THREE PLACES — ± 0.005	1:1	FE0C-F43BA-IW		
ANGLES — $\pm 1/2^\circ$	SHEET 1 OF 1			
HOSE ASSY. — $\pm 1\%$ DIAL				
FINISHED SURFACE 				
FILLETS & EDGES .02R OR CHAMF.				