

THIS DRAWING IS THE PROPERTY OF STRATO, INC.  
 THIS DRAWING IS LOANED UPON THE EXPRESS CONDITION THAT IT  
 SHALL NOT BE REPRODUCED IN ANY MANNER, AND SHALL BE RETURNED  
 UPON DEMAND. IT IS SUBMITTED FOR EVALUATION PURPOSES ONLY.  
 INFORMATION CONTAINED THEREIN, SHALL NOT BE USED, OR  
 DISCLOSED TO THIRD PARTIES WITHOUT THE WRITTEN CONSENT OF  
 STRATO, INC

# STRATO CLEARANCE VERIFICATION TOOL (EOCT-CVT) INSTRUCTION WORKSHEET

1. ADJUST THE LENGTH OF THE EOCT-CVT TO THE TRAVEL OF THE CUSHION UNIT BY USING THE SNAP BUTTON FEATURE.
2. ALWAYS HOLD THE CLEARANCE VERIFICATION TOOL HORIZONTALLY AND PARALELL TO THE LENGTH OF THE CAR.
3. MOVE ONE END OF THE TOOL ALONG ALL SURFACES FACING THE CENTER OF THE CAR.
4. VERIFY THERE IS ENOUGH CLEARANCE BETWEEN ANY MOVING PARTS AND OTHER CAR BODY STRUCTURES.
5. IF THE TOOL DOES NOT FIT BETWEEN ANY MOVING PART AND ANY STATIONARY PART, ADEQUATE CLEARANCE DOES NOT EXIST.
6. AFTER INSTALLATION, ALWAYS ENSURE PROPPER CLEARANCE OF ALL END OF CAR COMPONENTS TO ALLOW FOR FULL CUSHION UNIT TRAVEL PLUS 1/2".

(NOTE: ACTUAL ARRANGEMENT AND BRACKET ON CAR MAY DIFFER FROM COMPONENTS SHOWN IN ILLUSTRATION)

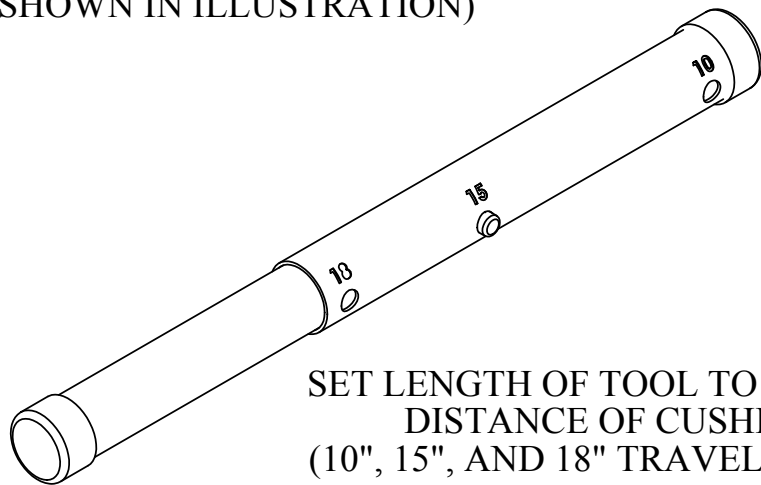
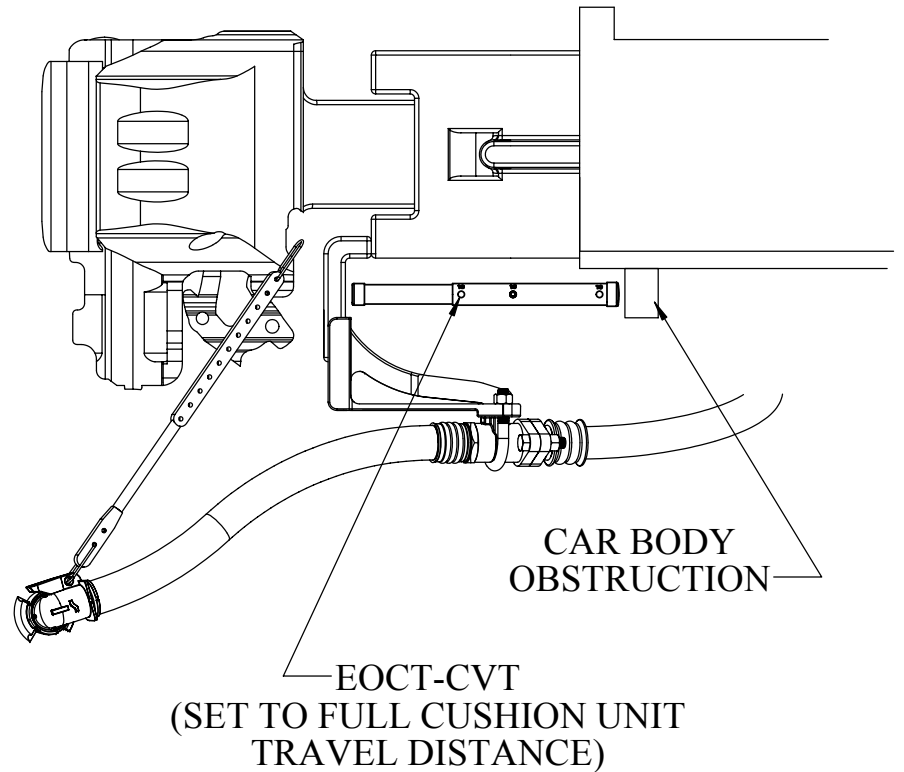

SET LENGTH OF TOOL TO FULL TRAVEL  
 DISTANCE OF CUSHION UNIT.  
 (10", 15", AND 18" TRAVEL INCREMENTS)

STATUS		 <b>Quality Railroad Products</b>		100 New England Avenue Piscataway, N.J. 08854	
RELEASED				SD-4 REV. F	
REFERENCE DRAWINGS		DESCRIPTION CLEARANCE VERIFICATION TOOL			
UNLESS OTHERWISE SPECIFIED TOLERANCES ARE AS FOLLOWS:		DRAWN BY JR		CHECKED BY LH	
FRACTIONS — ±1/32"		DATE		01/03/2006	
TWO PLACES — ±0.010		SCALE		DWG. NO.	
THREE PLACES — ±0.005		1:1		EOCT-CVT-IW	
ANGLES — ±2°		SHEET 1 OF 1		REV	
HOSE ASSY. — ±1% O.A.L.				0	
MACHINED SURFACE					
BREAK EDGES: 0.02" MAX.					
FILLET: R0.03" MAX.					

REV.	DATE	DESCRIPTION	ECN	INITIATED BY	APPROVED BY
------	------	-------------	-----	--------------	-------------